

CONTROLS

E2's units are designed for automation and are simple to connect. The following installation example shows connections and the peripheral equipment required by the units. When installing several pneumatically-operated units, we recommend that each unit have an individual sensor and individual main valves. The wiring circuit show which valves/sensors are integrated into the units.

BE 11 / HFS 100

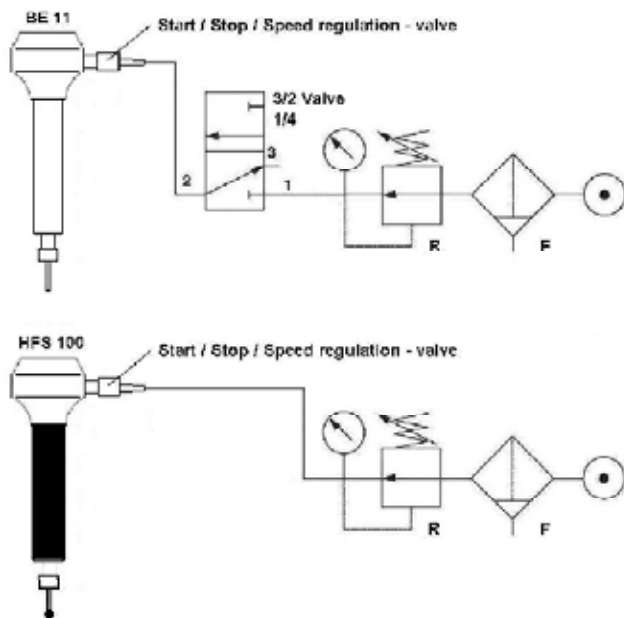

Working Pressure	4–6.3 bar
Air	Clean and dry

BE 22 SK(M) and 33 SK(M)

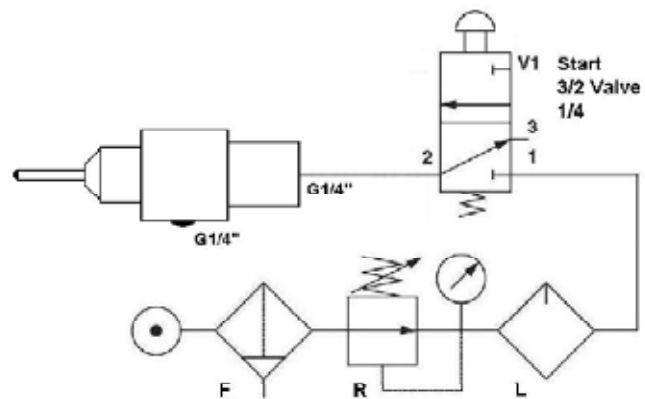

Working Pressure	6–7 bar
Air	Clean, dry and with oil mist (lubrication).
Options	Motor for air with no lubricator. Central silencer

Pneumatic limit switches

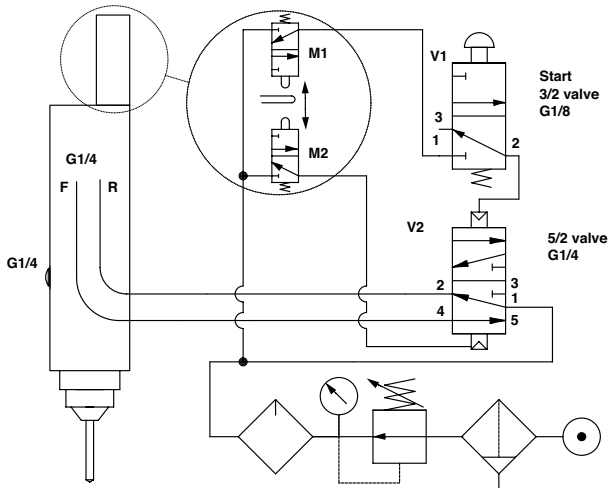

Electric limit switches

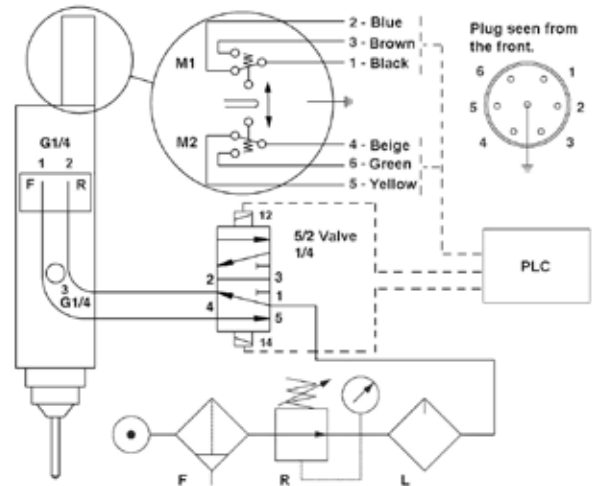

The max load for the switches at 220V is 1A.

The limit switches come with either 1.2 m hose (Pn) or 1.2 m cable (El).

We recommend a delayed return for accurate drilling depth tolerances and for countersinking.

The rotation of the spindle starts when the unit is fed air for forward feed. During the return the rotation gradually slows to a complete stop.

Working Pressure	6–7 bar
Air	Clean, dry and with oil mist (lubrication).
Options	Motor for air with no lubricator. Emergency break valve parallel to M2, which stops the unit and returns it to home position. Central silencer

On www.e2systems.com you can find more information as well as the same information as above in imperial units. When requesting a quote or ordering, please state: **Unit and Pneumatic or Electric switches.**

Pneumatic limit switches

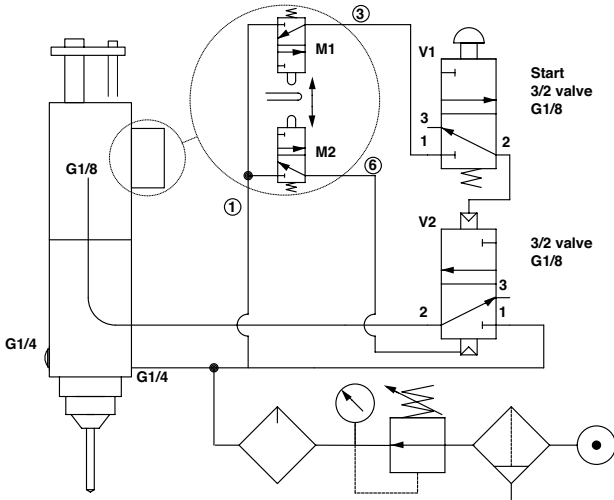

Electric limit switches

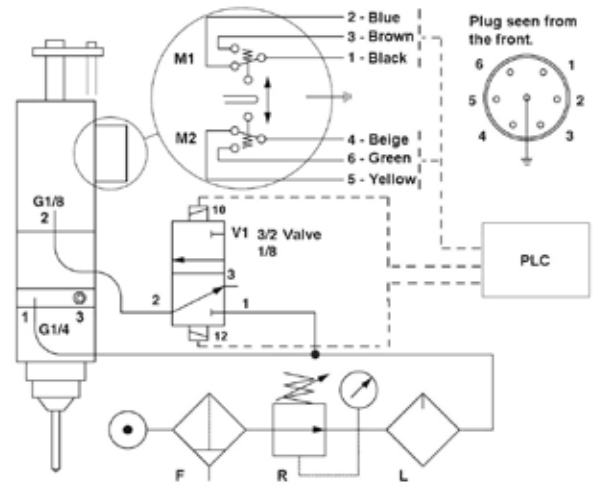

The max load for the switches at 220V is 1A.

The limit switches comes with either 2 m hose (Pn) or 2 m cable (El).

We recommend a delayed return for accurate drilling depth tolerances and for countersinking.

When the main valve is actuated, spindle feed and rotation commence. When the valve is released, the spindle returns to its start position and the motor's rotation ceases.

Working Pressure	6–7 bar
Air	Clean, dry and with oil mist (lubrication).
Options	Motor for air with no lubricator. Emergency break valve parallel to M2, which stops the unit and returns it to home position. Central silencer

Pneumatic limit switches

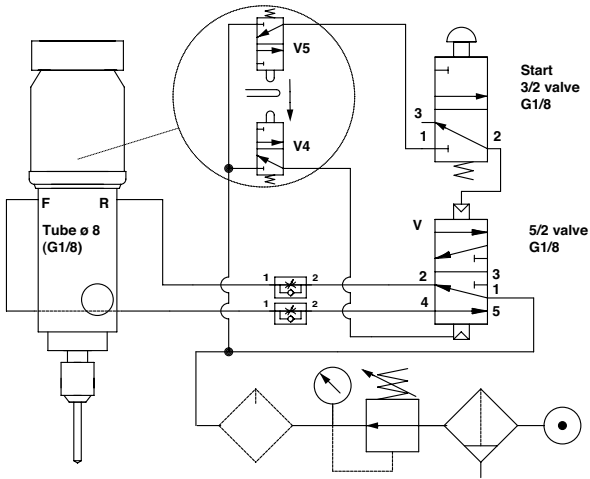

Electric limit switches or Linear transducer

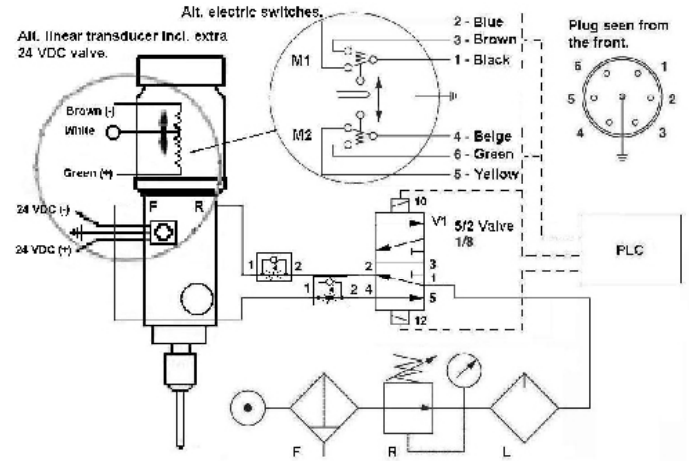

The max load for the switches at 220V is 1A.

Linear transducer (optional) for full control of the stroke. Ideal for the control of automatic chip removal, multiwall drilling, tapping, reaming etc.

The limit switches comes with either 2 m hose (Pn) or 2 m cable (El).

We recommend a delayed return for accurate drilling depth tolerances and for countersinking.

Working Pressure	Max 8 bar
Air	Clean and dry. Lubrication is not necessary but increases the life span of the unit.
Options	Emergency break valve parallel to V4 (unit returns to home position, the spindle must be shut off electrically)
Motor	The electrical motors are 3-phase and designed to work with both 50 and 60 Hz. Connect the motor via an overload cut-out to provide protection against overloading. Standard units can be operated via frequency converters, normally in the speed range 30–150 %. When tapping with reversible motor you must add a pole reversal contactor to the system.

On www.e2systems.com you can find more information as well as the same information as above in imperial units.

When requesting a quote or ordering, please state: **Unit and Pneumatic or Electric switches.**

BE 55 and BEG 55

Control systems and electrical connections:

The signal comes from the limit sensors of the BE(G) 55 from the control system. There is one sensor for the home and one for the extracted position. The drilling or tapping cycle/depth is controlled by a linear sensor which enables you to set the rapid feed distance, max drilling depth, chip-removal cycle and/or multi-wall drilling function.

There are two control systems to choose from:

C1A where you handle sensor signals and control valves externally (the control system has push buttons to manually control the valves for fast approach and controlled feed). Typically used together with PLC or similar.

C5A is a logic control system with integrated functions for normal cycle, chip removal and multi wall operation integrated. You only need a switch (impulse max 0.5 s) to start the operation. A ready signal will indicate when the cycle is completed.

The C5A control system and valve coils are designed for 230 V 50 Hz or 110V 50/60 Hz. The C1A control system is powered separately by 24 VDC. Both control systems are supplied with cables for connecting external controls.

Motors

The electrical motors are 3-phase and designed to work with both 50 and 60 Hz. Connect motor via an overload cut-out to provide protection against overloading. Standard units can be operated via frequency converters, normally in the speed range 30-150 %. Note: minimum motor speed with standard hydraulic gear pump is 500 rpm. When tapping with reversible motor you must add a pole reversal contactor to the system.

LS 11 and LS 22

Pneumatic limit switches

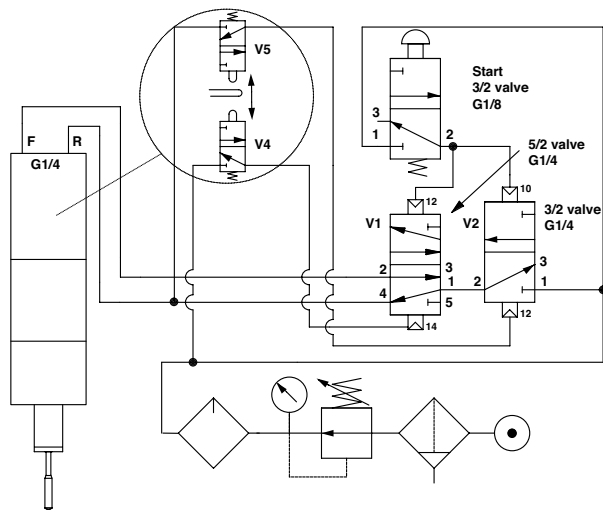

Electric limit switches

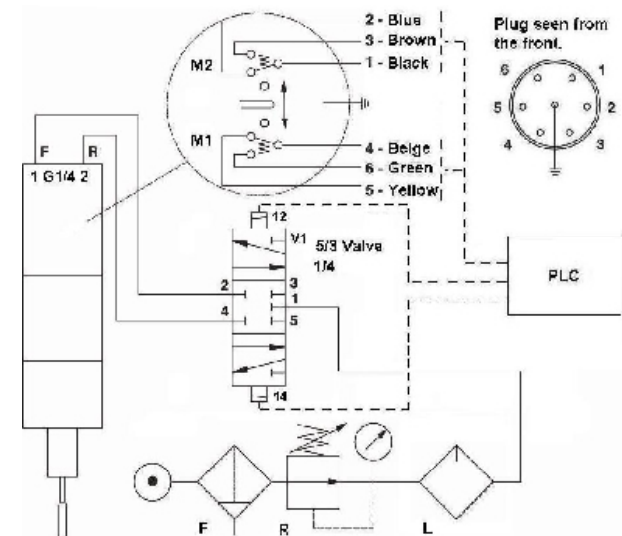

The max load for the switches at 220V is 1A.

The limit switches come with either 1.2 m hose (Pn) or 1.2 m cable (El).

Working Pressure	6-7 bar
Air	Clean, dry and with oil mist (lubrication).
Options	Motor for air with no lubricator. Emergency break 3/2 button. Connection from main to port 14 on valve V1 (unit goes to home position)

On www.e2systems.com you can find more information as well as the same information as above in imperial units.

When requesting a quote or ordering, please state: **Unit and Pneumatic or Electric switches.**